

# Evaluation Note for MCA1101/MCR1101

## $\pm 5A$ $\pm 20A$ $\pm 50A$ , 5V Isolated Current Sensors EVB EB0013 Rev A

©ACEINNA, Inc.

One Technology Drive, Suite 325, Andover, MA 01810, USA

Tel: +1-978-738-0900, Fax: +1-978-738-0196, [www.ACEINNA.com](http://www.ACEINNA.com)

Information furnished herein by ACEINNA is believed to be accurate and reliable. However, ACEINNA assumes no responsibility for its use, or for any infringements of patents or other rights of third parties resulting from its use. No license is granted by implication or otherwise under any patent or patent rights of ACEINNA. ACEINNA reserves the right to change this document without notification.

## DESCRIPTION

The EB0013 evaluation board provides a simple way to evaluate MCx1101 family of current sensor ICs. This double sided PCB with 4-ounce copper produces the low resistance path to the galvanically isolated primary current. An 8-pin connector P1 and test points enable users to easily access the signals of the secondary side bias and outputs. Two BNC outputs (VREF and VOUT) are intended to provide the low noise channels for VREF and VOUT signals to the oscilloscope or other test equipments.

## FEATURES

- **High Accuracy Current Sensor**
- **Superior Frequency Response (1.5 MHz 3dB BW)**
- **Fast output response time (300ns typical)**
- **Low Primary Resistance (0.9mΩ/50A and 1.3mΩ/5A/ 20A typical)**
- **5V Single Supply Operation**
- **Low power consumption (8mA typical)**
- **Overcurrent fault detection**
- **SOIC-16 package (RoHS/REACH compliant)**
- **-40°C to +105°C Operating Temperature Range**
- **UL/IEC/EN60950-1 Certified**
  - ✓ **4.8 kV Dielectric Strength Voltage**
  - ✓ **1097 VRMS Basic Isolation Voltage**
  - ✓ **400 VRMS Reinforced Isolation Voltage**

## ORDER INFORMATION

EVB PART NUMBER	Current Range	Gain	Voltage
EVB MCA1101-5-5	+/-5 Amp	Fixed	5V
EVB MCA1101-20-5	+/-20 Amp	Fixed	5V
EVB MCA1101-50-5	+/-50 Amp <sup>Note1</sup>	Fixed	5V
EVB MCR1101-5-5	+/-5 Amp	Ratiometric	5V
EVB MCR1101-20-5	+/-20 Amp	Ratiometric	5V
EVB MCR1101-50-5	+/-50 Amp <sup>Note1</sup>	Ratiometric	5V

Note1: ±50A Plus

## TEST BOARD PIN DESCRIPTION

Name	Connection	Description
I_IN	Fix the wire of Primary Current by screw	Non-Inverting Current Sense Input
I_OUT	Fix the wire of Primary Current by screw	Inverting Current Sense Input
VOC	P1 Connector Pin 1	Input pin. Voltage on this pin defines the OCP threshold level.
VCC	P1 Connector Pin 2	Sensor power supply.
VOUT	P1 Connector Pin 3	Analog Output Signal linearly proportional to Primary Path Current
VREF	P1 Connector Pin 4	Zero Current Analog Reference Output
GND	P1 Connector Pin 5	Ground.
TEST1	P1 Connector Pin 6	For factory calibration only. Do not connect.
TEST2	P1 Connector Pin 7	For factory calibration only. Do not connect.
FAULTB	P1 Connector Pin 8	Output pin, active low when the primary current exceeds the setting threshold

## OPERATING INSTRUCTIONS

- Connect power supply to positive terminal and negative terminal to VCC and GND of P1, respectively
- Connect multimeter, oscilloscope, or other signal measurement devices to VOUT, VREF and GND through either P1 connector, test points, or BNC connectors
- Connect current to be measured to the I<sub>IN</sub> and I<sub>OUT</sub> Primary Wires. For correct positive/negative current readings, positive current should flow from I<sub>IN</sub> to I<sub>OUT</sub>.
- To read sensor output, VOUT, VREF, and VCC voltages must be measured and converted to a current per the electrical characteristics table.

### Note:

- This EVB is designed to work up to 50A peak (35A RMS) for thermal reasons. In order to evaluate the performance with 35 -50A DC, use pulsed current with appropriate duty cycle that guarantees no more than 35A RMS.
- High current will cause sensor IC and PCB to be very hot. The junction temperature can exceed 100°C. **Do not touch the chip and PCB.** The temperature rise can be reduced by using thicker cable and bigger screws.

## SCHEMATIC

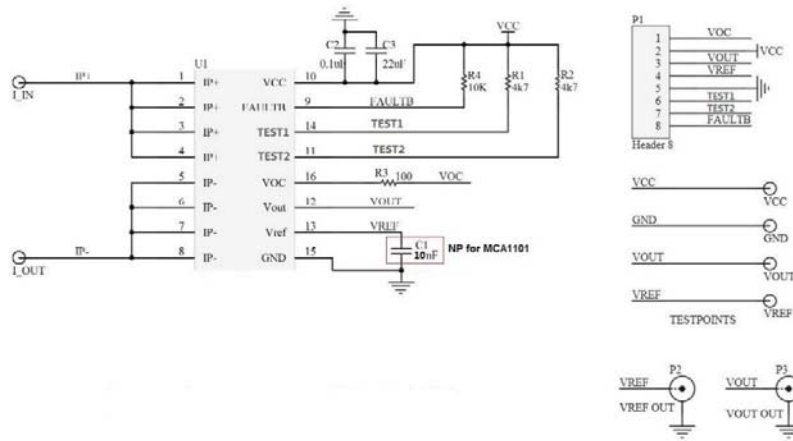

## PCB LAYOUT – TOP SIDE

